

McDonnell-Miller 150 & 157 Cut-Off/Pump Control

Snap Switch Models

Mercury Switch Models Discontinued!



150 Series

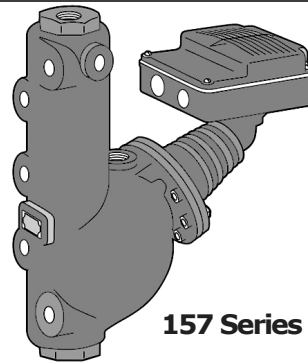
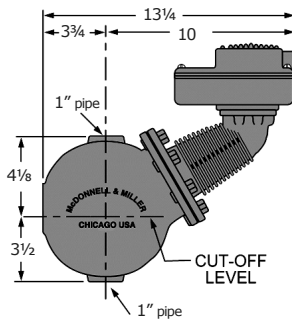

157 Series

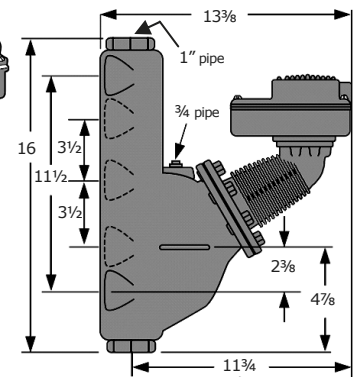

Complete Model 150 and 157 and Head Mechanisms

Model No.	Description	Complete Order No.	Head Mechanism
150S & 157S with Snap Switches			
150S	Cut-Off/Pump Controller—Snap	MH1095	MI1145
150S-M	150S With manual reset	MH1097	MI1147
150S-MD	150S with Maximum Differential — Prevents nuisance burner shutdown	MH1096	MI1147A
150S-M-MD	150S-MD with manual reset	172802	MI1147B
157S	150S with built-in water column	MH1100	MI1145
157S-M	157S with manual reset	MH1102	MI1147
157S-MD	157S with Maximum Differential — Prevents nuisance burner shutdown	MH1103	MI1147A
157S-M-MD	157S-MD with manual reset	175412	MI1147B
157SRBPMD	157S-MD w/integral sensing probes	MH1104	*MI1147A
158 & 159 with Double Snap Switches			
158-S	150S with 2 SPDT switches	MH1105D	MI1148B
158-S-M	150S with manual reset	178502	MI1148C
159-S	150S with 2 SPST switches	MH1105F	MI1149B
Replacements for Old Style 150 & 157 with Mercury Switches <i>Replacement Snap Switch models shown.</i>			
150	Cut-off/Pump Controller—Mercury	MH1095	MI1145
150-M	150 with manual reset	MH1097	MI1147
150-MD	150 with Maximum Differential — Prevents nuisance burner shutdown in low-pressure applications	MH1096	MI1147A
150-M-MD	150 with manual reset and maximum differential for low pressure	172802	MI1147B
157	150 with built-in water column	MH1100	MI1145
157-M	157 with manual reset	MH1102	MI1147
157-MD	157 with maximum differential	MH1103	MI1147A
157-M-MD	157 with manual reset and maximum differential for low pressure	175412	MI1147B
157RBPMD	157MD with integral sensing probes	MH1104	*MI1147A
Replacements for Old 158 & 159 with Double Mercury Switches <i>Replacement Snap Switch models shown.</i>			
158	150 with 2 SPDT mercury switches	MH1105D	MI1148B
158-M	158 with manual reset	178502	MI1148C
159	150 with 2 SPST mercury switches	MH1105F	MI1149B

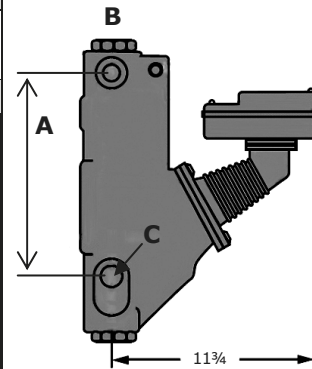

157R & 157RL side-mount gage glass tappings

Gauge glass tappings are located on the side of the body on both the 157R and 157RL.

Tapping Sizes and "A" for Series 157

Product No.	157	157A	157RL
A Dimension	11 1/2"	11 1/2"	12 3/4"
B Equalizing tappings	1" npt	1 1/4" npt	1 1/4" npt
C Gauge glass & tri-cock tappings	1/2" npt	3/4" npt	1/2" npt

Head Mechanism

Convert your old mercury models into Snap-Switch models:

Replace the head mechanism!

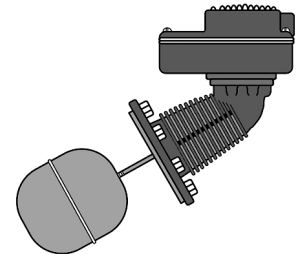

Features of 150 and 157

■ Mercury switch models are no longer available for sale as of April 7, 2007 due to "hazardous material" classification.

- For steam boilers any steaming capacity in low or high pressures.
- Model 157 has a built-in water column
- Units with Snap Switches are Mercury Free! The snap switch replaces the old, hazardous material mercury switches.
- Units with Manual Reset need to be "manually reset" to an operational condition after a low-water condition shuts down burner.
- Max. steam operating pressure, 150 psi.

*Order the integral sensing probes separately

McDonnell-Miller 150 & 157 Repair Parts

No. 150 & 157 Repair Parts — Mercury Switches

No. 150S & 157S Repair Parts — Snap Switches

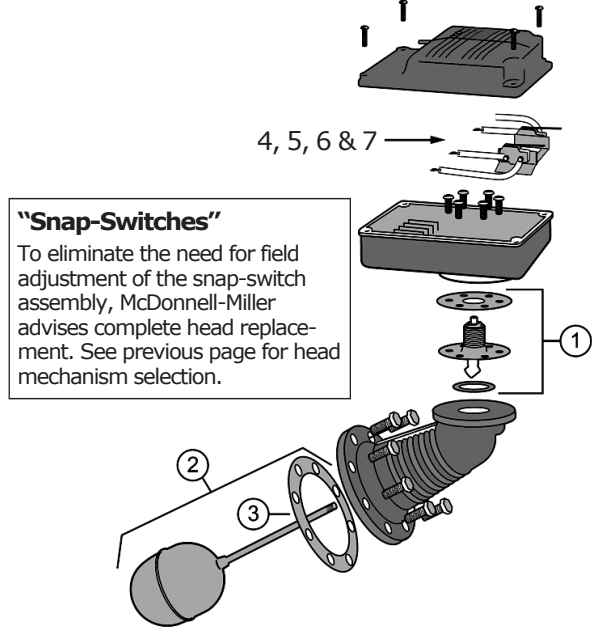
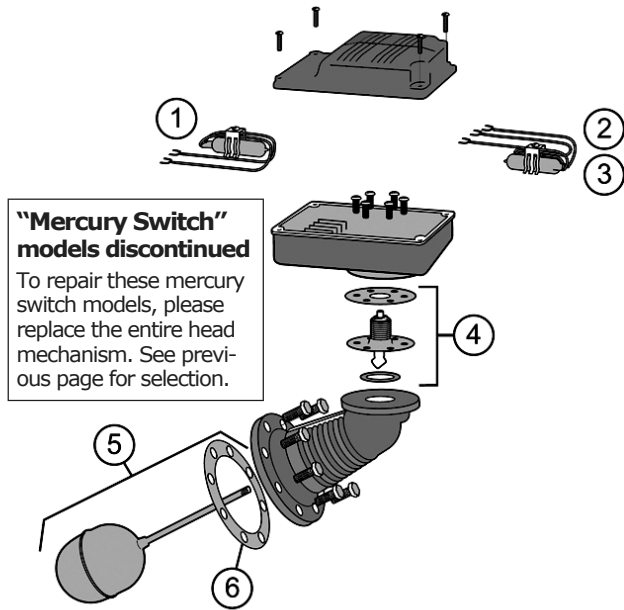

Repair Parts for 150 & 157 Mercury Switch		
Part No.	*Mercury Discontinued 04/07/07	Order No.
1	Mercury switch, 2-wire	No longer available.
2	Mercury switch, 3-wire	
3	Mercury switch, 3-wire, manual reset	
4	Bellows assembly	MI1360
5	Float & rod assembly (includes gasket)	MI1355
6	Head Gasket (standard ring gasket)	Use MI1140
7	Head Gasket (8-hole bolt gasket)	MI1140
Repair Electrodes for the 157-BRP		
8	Short electrode for 157-RBP only	MI1176A
9	Long electrode for 157-RBP only	MI1176
10	Level control module for 157-RBP only	MI1530

Repair Parts for 150S & 157S Snap Switch		
Part No.	Description	Order No.
1	Bellows assembly	MI1360
2	Float & rod assembly (includes gasket)	MI1355
3	Head Gasket (8-hole bolt gasket)	MI1140
4	Snap switch for 150S	MI1376
—	Snap switch for 150S-MD <i>Not shown</i>	MI1377A
5	Snap switch for 150S-M styles	*N/A
6	Snap switch for 158S styles	MI1378
7	Snap switch for 158S-M styles	310469
—	Snap switch for 159S <i>Not shown</i>	MI1378B

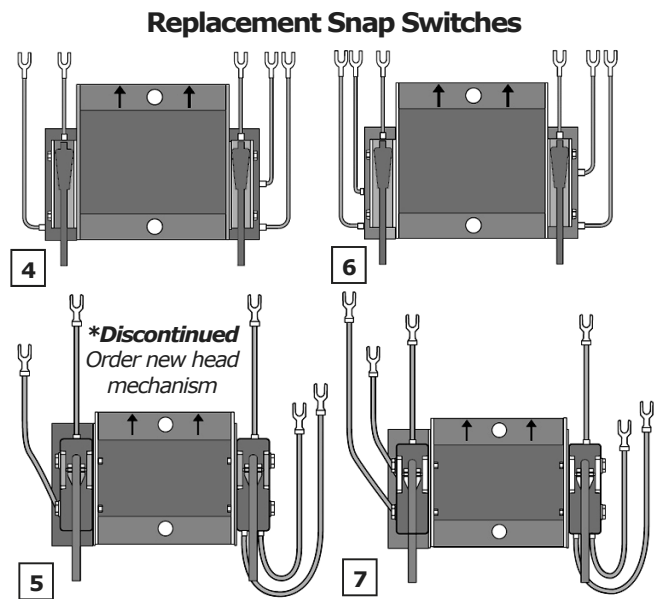
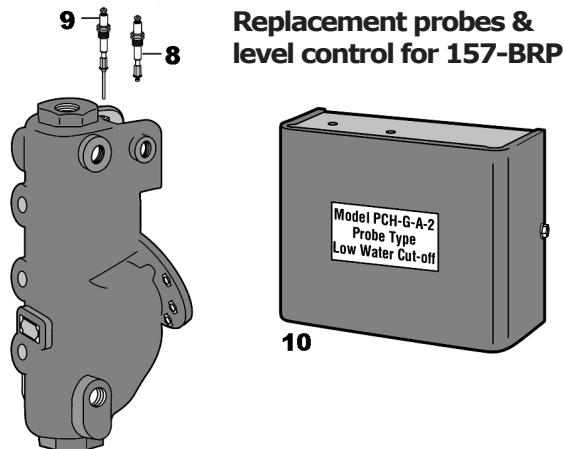

Convert Your Old 150 or 157 Mercury or Snap Models



Convert your old Mercury or Snap-Switch Models into New Electronic Probe Control Models!

Replacement 150E Head Assemblies

Model No.	Description	Head Assembly
150E	Cut-Off/Pump Controller	MI1141A
150E-M	150E With Manual Re-set	MI1141B

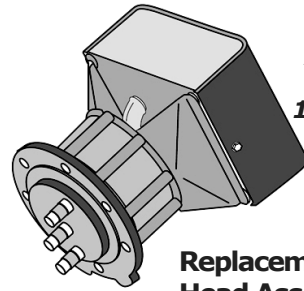

Fits on your old 150 and 157 units!

Replacement 150E Head Assembly

Wiring connections for a Series 150E/157E when used as a replacement for a Series 150/157 (mercury) or 150S/157S (snap) switch unit.

NOTE

Read and follow installation instructions included with 150E/157E control.

- A. Connect 'Hot' (L1) wire from power supply to Terminal 'H'.
- B. Connect 'Neutral' (L2) wire from power supply to Terminal 'N'.

NOTE: Power wires connected to Terminals 'H' and 'N' on 150E should be from the boiler's control transformer connections which are usually designated 'L1' and 'L2'. The 150E **SHOULD NOT** be powered as part of any operating or safety circuit.

- C. Remove wire from Terminal '1' and connect to Terminal 'PCOM'.
- D. Remove wire from Terminal '2' and connect to Terminal 'PNO'.
- E. Remove wire from Terminal '4' and connect to Terminal 'BNC'.
- F. Remove wire from Terminal '5' and connect to Terminal 'BCOM'.
- G. Remove wire from Terminal '6' and connect to Terminal 'BNO'.

Snap Switches (Series 150S and 157S)

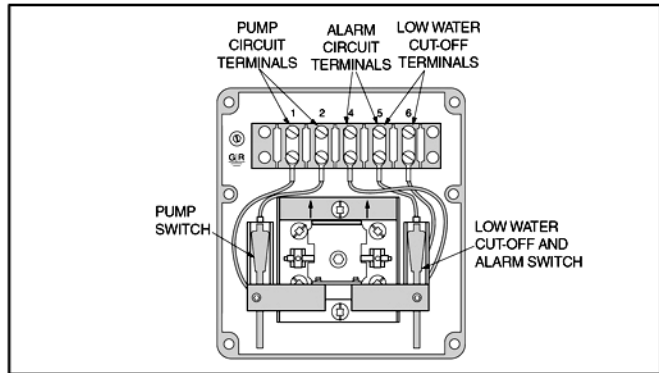

Mercury Switches (Series 150 and 157)

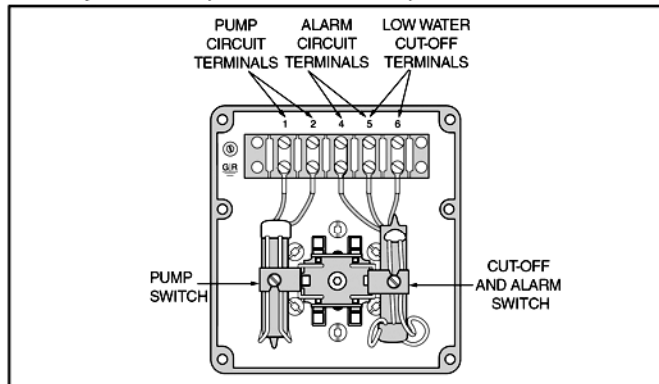

Electronic Relays (Series 150E and 157E)

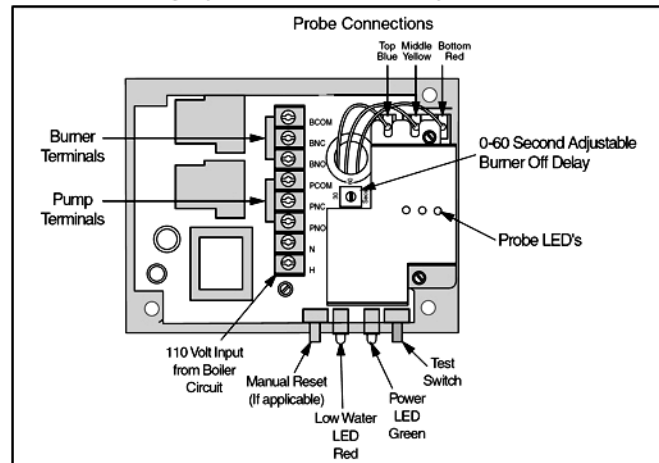

McDonnell-Miller 150E and 157E Boiler Controls

The Future Has Arrived! No more mechanical operation!

ESPECIALLY GREAT FOR BOILERS WITH RAPIDLY FLUCTUATING WATER LINES — FEATURES:

■ Primary and secondary low water cut-off protection and pump control for commercial and industrial steam boilers ■ Great for applications with rapidly shifting water levels ■ Ideal for vertical tubeless, water tube, process and smaller fire tube boilers ■ Conductance probe level detection ■ Maintains differentials throughout pressure range ■ Internal diagnostics to monitor operation ■ Field adjustable burner-off time delay that prevents nuisance shutdowns by compensating for shifting water lines ■ Maximum pressure – 150 psi.

Low Water Cut-Off and Pump Controller

Get the reliable operation you need — even if you have a volatile, fluctuating boiler water line. The NEW 150E and 157E (with integral boiler column) utilizes a conductance water-sensing probe (in place of a float), allowing the 150 to compensate for a fluctuating boiler water level. The conductance probe can prevent unnecessary burner and pump action, thereby preventing nuisance burner shutdowns.

Conductance probes detect varying water level conditions to control both pump and burner operations.

157E with Integral Water Column

150E

The 157E and 150E include:

- Internal diagnostics to monitor operation,
- Adjustable pump differentials to meet different system applications,
- No "lockout" after power outage if water is on the probe,
- Field adjustable burner-off time delay prevents nuisance shutdowns by compensating for shifting water lines,
- CSD-1 compliant and Mercury free!

See Ordering Guide on the Following Page

Series 150E & 157E Electric Cut-Off/Pump Control

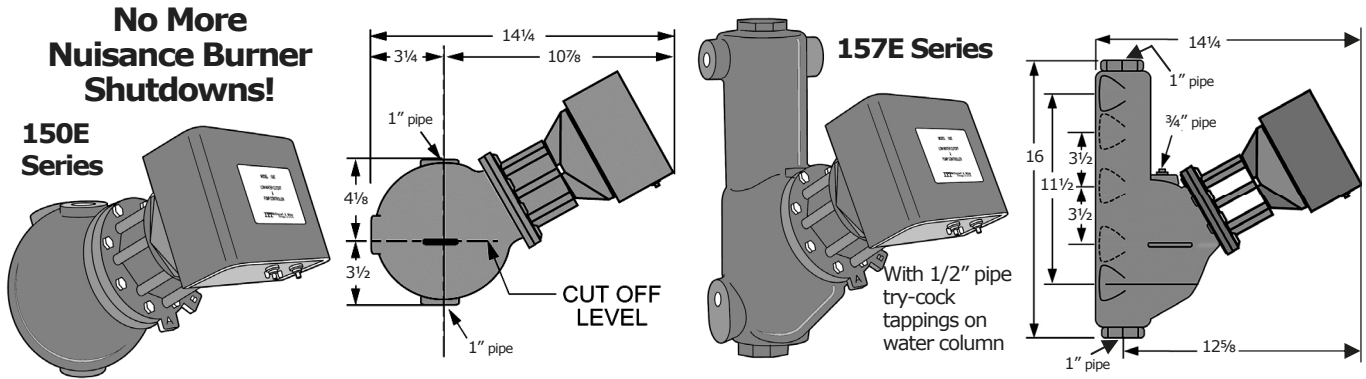

Complete Model 150E and 157E and Head Mechanisms			
Model No.	Description	Complete Order No.	Head Assembly
150E	Cut-Off/Pump Controller—Snap, #171600	MH1091A	MI1141A
150E-M	150E With manual reset, #171610	MH1091B	MI1141B
157E	150E with built-in water column, #171620	MH1091C	MI1141A
157E-M	157E with manual reset, #171630	MH1091D	MI1141B

No more nuisance burner shutdowns due to volatile, fluctuating boiler water lines!

If you have one of those boilers where the water line fluctuates like a roller coaster, your problems are over . . .

Utilizing conductance water sensing probes (in place of float operation) the *NEW* Model 150E detects varying water level conditions to efficiently control both pump and burner operation.

Prevent nuisance burner shutdowns and get efficient boiler operation.

Select from automatic or manual re-set.

Electrical Rating and Switch Ratings

Supply Voltage	Probe Voltage	Full load (Amps) NO (NC), VAC	Locked Rotor (Amps) NO (NC), VAC	Pilot Duty (VA) NO (NC), VAC	Motor (HP) NO (NC), VAC
120 VAC	5 VAC	16 (5.8), 120	96 (34.8), 120	470 (290), 120	1 (1/4), 120
50/60 Hz	Maximum	8 (4.9), 240	48 (17.4), 240	470 (290), 120	2 (1/2), 240

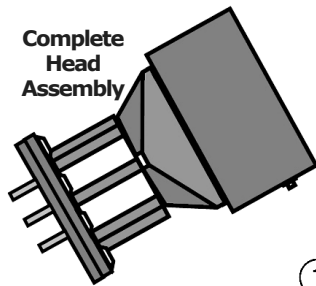

150E and 157E Repair Parts

Not many parts to deal with here! Order the flange probe assembly (1), the control unit (2) or the complete head assembly.

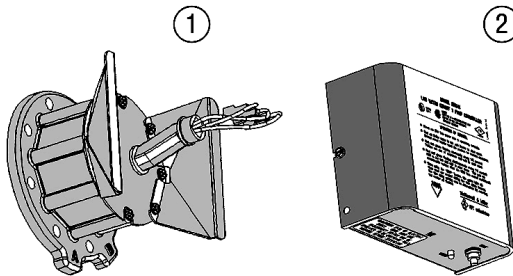

Applications & Features for the 150E and 157E:

- Primary or secondary pump controller/low water fuel cut-off for steam boilers
- Motorized valve controller
- Low water and high water cut-off
- Dual pump control
- Alarm actuator

Burner Relay Time Delay

There is a field-adjustable time delay (DOB) to prevent nuisance burner shut-down. The number of seconds water needs to be off the bottom probe before the burner relay is deactivated can be field adjusted between 0 and 60 seconds.

Redundant Low Water Cut-Off

When the boiler water drops below the middle probe, a 3 minute timing circuit will be activated. If water does not return to the middle probe within three minutes, the burner relay will deactivate. The Red LED will flash once every second if this condition occurs.

- Automatic Reset units will automatically reset when the water level is restored to the middle probe.
- The reset button on Manual Reset units will have to be pressed after water is restored to the middle probe.

Redundant Pump Off

The pump relay will be activated after water drops below the middle probe. If the water level is not restored to the top probe within 3 minutes the pump relay will be deactivated. After the pump relay is deactivated, normal operation is resumed. Water must again drop off the middle probe to activate the pump relay. There is no LED signal for this occurrence.

Repair Parts for 150E and 157E

Item	Description	Order No.
1	Flange and Probe Assembly	MI1140F
2	Control Unit	MI1140E
3	Head-to-Bowl Gasket	MI1140
Manual Re-set Complete Head Assembly		MI1141A
Automatic Re-set Complete Head Assembly		MI1141B